

Yale[®]

By Columbus McKinnon

LODEKING[™] LT

ELECTRIC WIRE ROPE HOISTS

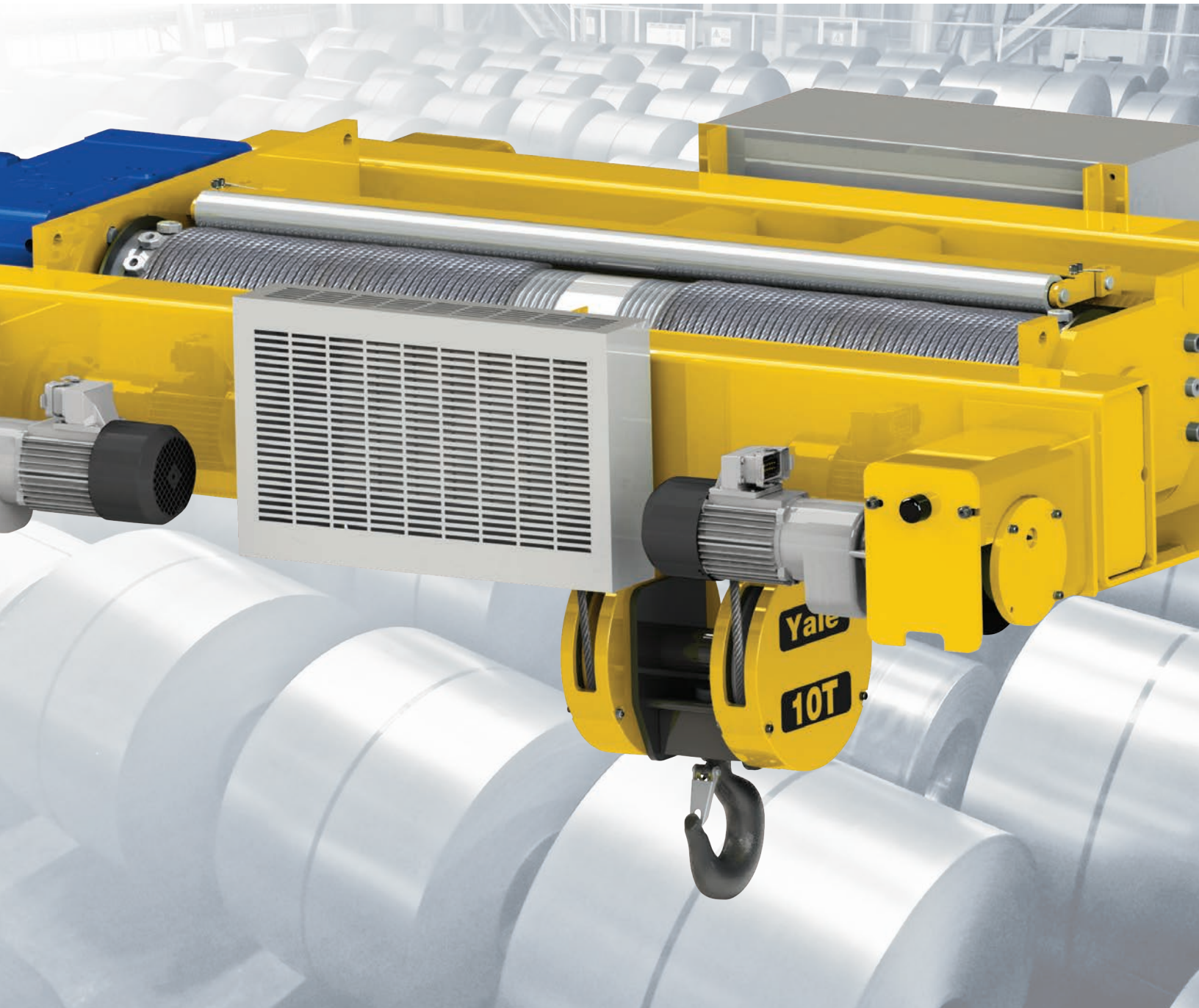

C O L U M B U S M C K I N N O N C O R P O R A T I O N

Yale® LodeKing LT™ wire rope hoists combine the durability you have come to expect from Yale with the higher capacities your applications demand.

Built with almost 150 years of engineering know-how, these best-in-class hoists combine the latest manufacturing and materials technology with the highest quality components for unsurpassed performance and reliability.

The LodeKing LT is designed for heavy-duty CMAA Class D service. These hoists feature industry-leading Magnetek® closed-loop variable frequency drives, allowing for accurate and precise load control while reducing brake wear.

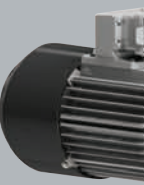
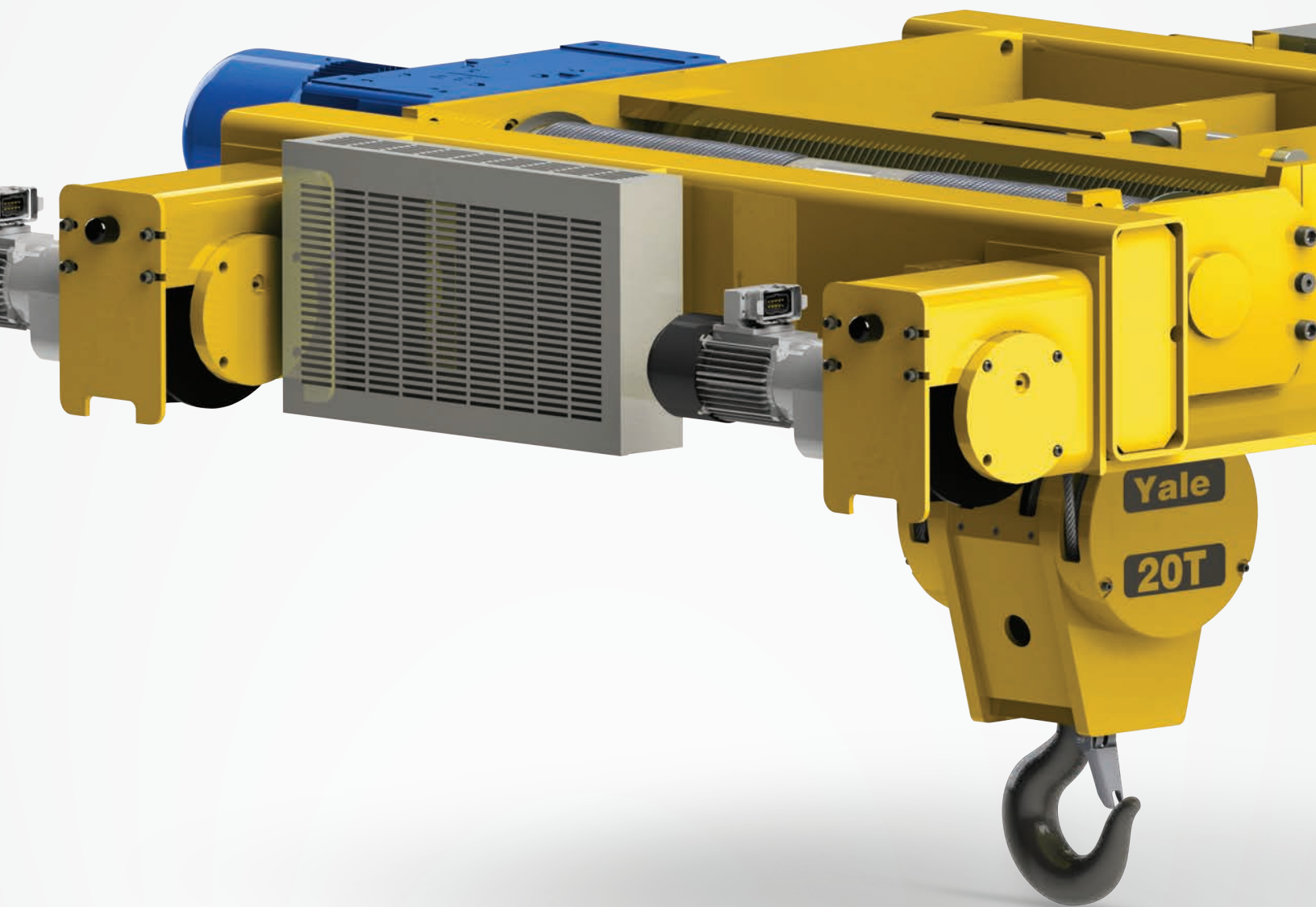

TABLE OF CONTENTS

Electric Wire Rope Hoists (Low-Headroom Models)

Magnetek IMPULSE®-VG+ Series 4 Drives

Intelli-Connect™ Mobile: Wireless Drive Monitoring, Analytics, and Configuration



LODEKING LT[™]

ELECTRIC WIRE ROPE HOISTS

The Yale® LodeKing LT™ wire rope hoist provides high-quality performance and durability in an ultra-low-headroom design, making it the ideal choice when purchasing a new or replacement hoist for applications with space limitations.

The LodeKing LT features plastic-infused wire rope that prevents metal-to-metal contact between strands, helping to reduce abrasion and wear within the wire rope.

Manufactured in Wadesboro, North Carolina, LodeKing LT low-headroom models are available in capacities from 10 to 25 tons and, depending on your application needs, are available in economical, low-horsepower top running and deck mount models.

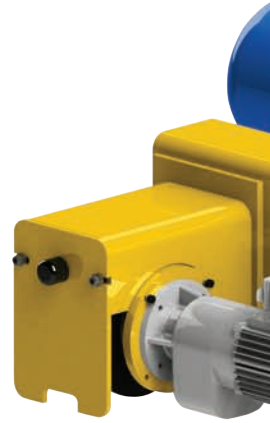

CAPACITIES 10 to 25 TONS

KEY SPECIFICATIONS

Feature	LodeKing LT
Service Class	CMAA Class D, ASME / HMI – Class "H4"
Design Safety Factor	5:1 (min.)
Bottom Block Sheave-to-Rope Ratio	~22:1 (min.)
Operating Environment	Indoor
Hook Assembly	360° rotation with safety latch
Rope Guide	No
Drum	Steel drum w/nominal 50% groove depth ~21:1 (min.) drum-to-rope ratio
Safety Wraps	3
Hoist Control	Closed-Loop (Flux Vector) VFD

Feature	LodeKing LT
Hoist Limit Switches	Two-position rotary cam upper/lower type plus upper block type limit switch
Trolley Control	Open-Loop VFD
Trolley Brake	Included
Control Enclosure	NEMA 4/12
Voltages	Line: 460-3-60 • Optional 208-3-60, 230-3-60 & 575-3-60 • Control: 115-1-60
Pendant	Not included as standard
Bearings	Sealed and/or shielded, lifetime lubricated
CSA Approval	Optional
UL Approval	No

STANDARD FEATURES

- 1 TRUE VERTICAL LIFT**
Better load control. Easy movement and placement of product.
- 2 HEAVY-DUTY STEEL DRUM**
50% groove depth to guard against rope jumping out of groove.
- 3 INDUSTRY-PROVEN GEAR DRIVE**
Easy-to-maintain gear drive features a sight glass for quick inspection of the oil level. Standard availability improves product lead time.
- 4 EXCEEDS CMAA CLASS D ROPE TO SHEAVE & DRUM DIAMETER**
Reduces rope maintenance.
- 5 TROLLEY VFD CONTROL STANDARD ON ALL UNITS**
Allows for smooth acceleration and deceleration.
- 6 SUPPLEMENTAL UPPER & LOWER LIMIT SWITCH**
Safely stops load from being lifted or lowered beyond set limits, reducing damage to equipment and hoist.
- 7 STANDARD FLUX VECTOR HOIST DRIVE PACKAGE**
Improves load control and allows for precise movements. Reduces brake wear.
- 8 200% MOTOR BRAKE TORQUE RATING**
Secondary brake exceeds CMAA Standards. Stops and holds a rated load quickly and securely.
- 9 EXTERNAL HOIST BRAKE RESISTOR**
Allows for dynamic braking and uninterrupted drive service at high duty cycles. Hoists are not equipped with load brakes, reducing heat generation in high-duty-cycle applications.
- 10 15 TO 25 HP MOTORS AVAILABLE**
Offers wide range of hoist lifting speeds.

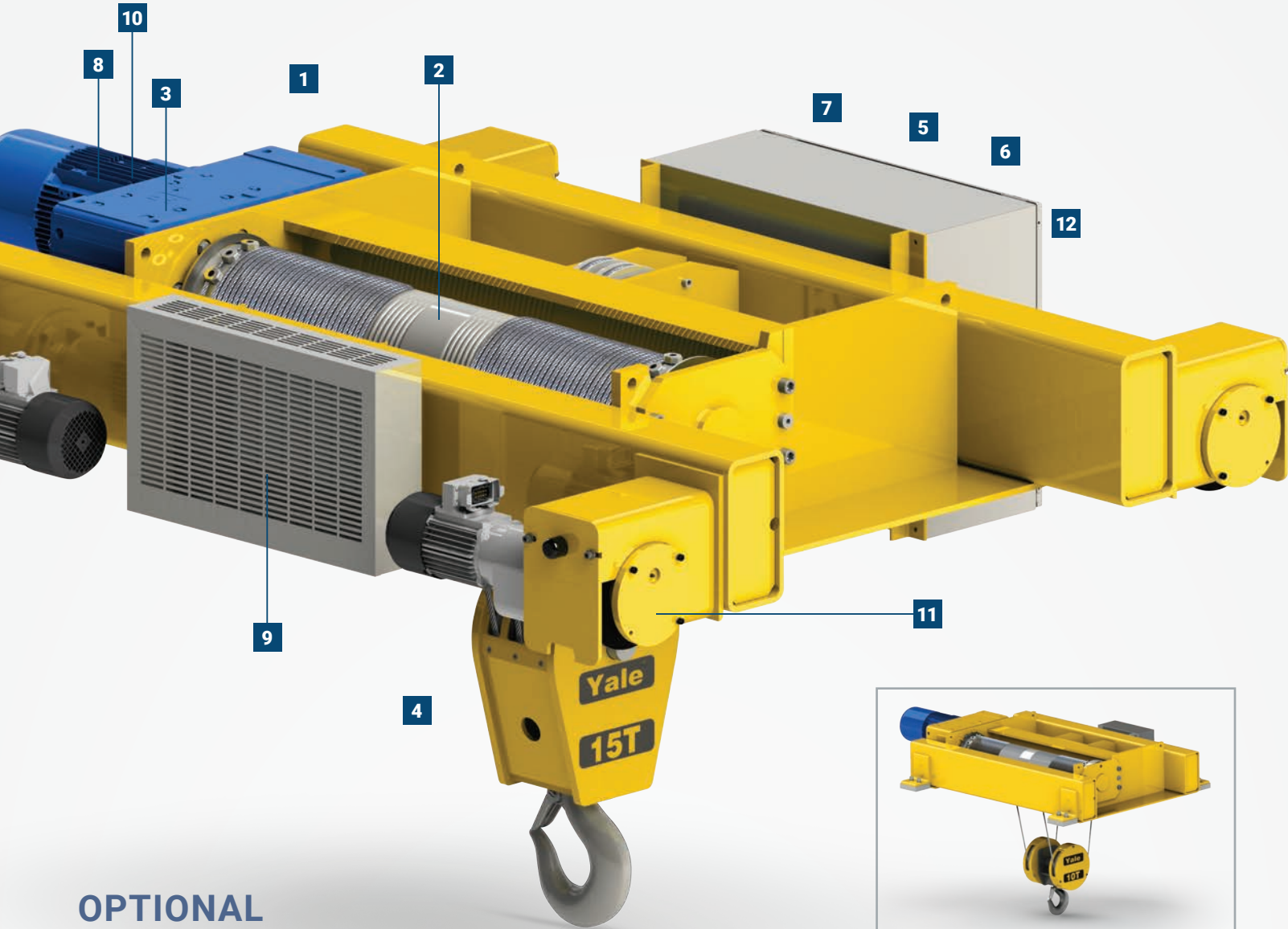

OPTIONAL CSA APPROVAL

DECK MOUNT LODEKING LT

OPTIONAL FEATURES

- 11 WHEEL BLOCKS USING INTEGRAL AXLE TROLLEY WHEEL COMPONENTS**
Ideal for Class D service requirements. Ball bearings used on 10-ton capacity and roller bearings used for 15 through 25-ton capacities.
- 12 THERMAL OVERLOAD PROTECTION**
Provided within the drive.

- LOAD SENSING**
Standard field programmable.
- AUXILIARY HOLDING BRAKE**
- WIDE RANGE OF LIFTS & TROLLEY GAUGES**
- OVERLAY PROTECTION WITH SPOOLING BAR**

FEATURES AND SPECIFICATIONS

Features	Capacity (US Tons)			
	10	15	20	25
Standard Lift (ft.)	49.0	34.0	24.0	23.0
Hoist Lifting Speed (FPM)	21	14	10	9
Optional Lifting Speeds Available (FPM)	29, 35	19, 23	14, 17	11, 15
Standard Hoist Motor HP	15	15	15	15
Standard Gauge (in.)	60	60	60	60
Trolley Drive Type	VFD	VFD	VFD	VFD
Trolley Speed (FPM)	100	100	100	100
Trolley Motor HP	1.5 (x2)	1.5 (x2)	2 (x2)	2 (x2)
Technical Specifications	Capacity (US Tons)			
	10	15	20	25
Hoist				
Hoist Motor Duty	S3-60% Duty	S3-60% Duty	S3-60% Duty	S3-60% Duty
Hoist Full Load Amps @ 460V Power	21.9	21.9	21.9	21.9
Hoist Inverter Amps @ 460V Power	24	24	24	24
Hoist Motor RPM	1,740	1,740	1,740	1,740
Hoist Bearing Life (hrs.)	10,000	10,000	10,000	10,000
Standard Hoist Motor Frame Size (IEC Designations)	132MC	132MC	132MC	132MC
Hoist Motor Torque Rating (Brake Rating 200% Min.)	150Nm (247%)	150Nm (247%)	150Nm (247%)	150Nm (247%)
Hoist Motor Brake Type	DC	DC	DC	DC
Manual Release Type	Yes (Spring Return To On)	Yes (Spring Return To On)	Yes (Spring Return To On)	Yes (Spring Return To On)
Motor Insulation Class	F	F	F	F
Hoist Thermal Overload Protection	TAS In Motor & Thermal Overload Provided By VFD			
Number of Reductions on Gear Drive	3	3	3	3
Helical Gear or Combination Helical & Spur	Helical	Helical	Helical	Helical
AGMA Standard	AGMA Class 13	AGMA Class 13	AGMA Class 13	AGMA Class 13
Gear Case Material	Gray Iron	Gray Iron	Gray Iron	Gray Iron
Overhung Gearing	No	No	No	No
Parts of Rope	4	6	8	8
Rope Diameter (mm)	12	12	12	13
Wire Rope Drum Material	Steel	Steel	Steel	Steel
Wire Rope Drum Diameter (in.)	10	10	10	10.5
Wire Rope Drum Groove Depth (%)	50	50	50	50
Upper Block Sheave Material	Steel	Steel	Steel	Steel
Upper Block Sheave Diameter (in.)	10.63	10.63	10.63	10.63
Removable from Upper Sheave Nest	Yes	Yes	Yes	Yes
Lower Block Sheave Material	Steel	Steel	Steel	Steel
Lower Block Sheave Diameter (in.)	10.63	10.63	10.63	10.63
Roller Thrust Bearing	Yes	Yes	Yes	Yes
Hook Material	Alloy	Alloy	Alloy	Alloy
Trolley				
Operate on Both ASCE Rail & Square Bar	Yes	Yes	Yes	Yes
Maximum One Wheel Load (lbs.)	6,800	9,900	12,000	14,600
Trolley Wheel Diameter (mm)	200	200	260	260
Trolley Wheel Hardness (BHN)	300-350	300-350	300-350	300-350
Trolley Full Load Amps @ 460V Power	2.3A (x2)	2.3A (x2)	3.2A (x2)	3.2A (x2)
Trolley Inverter Amps @ 460V Power	4.8A	4.8A	9.2A	9.2A
Trolley Motor RPM	3,960/72.8	3,960/72.8	1,670/37.4	1,670/37.4
Trolley Motor Frame Size	D71	D80	D90L	D90L
Trolley Bearing Life (hrs.)	10,000	10,000	10,000	10,000
Trolley Motor Torque Rating (Brake Rating 50% Min.)	2.5Nm (86.5%)	2.5Nm (86.5%)	10Nm (116.6%)	10Nm (116.6%)
Trolley Motor Duty	S3-40%	S3-40%	S3-40%	S3-40%
Trolley Motor Insulation Class	F	F	F	F
Trolley Thermal Overload Protection	TAS In Motor & Thermal Overload Provided By VFD			
Axle Bearings	Roller	Roller	Roller	Roller
Trolley Motor Brake Type	DC	DC	DC	DC
Trolley Manual Release Type	N/A	N/A	N/A	N/A

ULTRA-LOW HEADROOM

The LodeKing LT features an ultra-low-headroom design and is the ideal choice when purchasing a new or replacement hoist for applications with space limitations.

10-TON MODELS

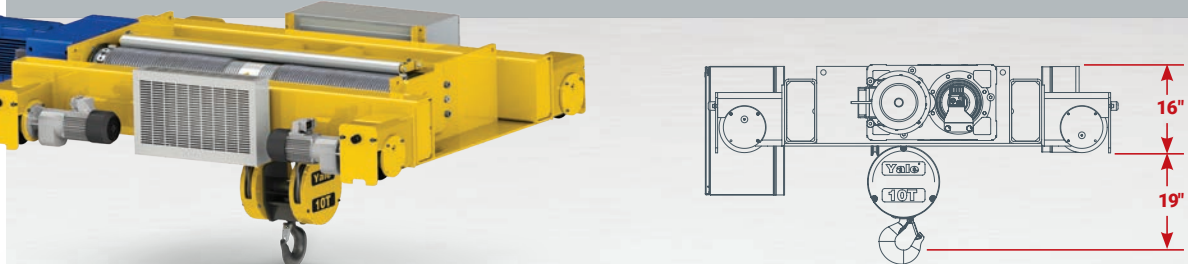

*Shown with optional Spooling Bar

TOP OF RAIL TO TOP OF HOIST: 16 in.
TOP OF RAIL TO HOOK SADDLE: 19 in.

15-TON MODELS



TOP OF RAIL TO TOP OF HOIST: 16 in.
TOP OF RAIL TO HOOK SADDLE: 27 in.

20-TON MODELS



TOP OF RAIL TO TOP OF HOIST: 16 in.
TOP OF RAIL TO HOOK SADDLE: 31 in.

25-TON MODELS

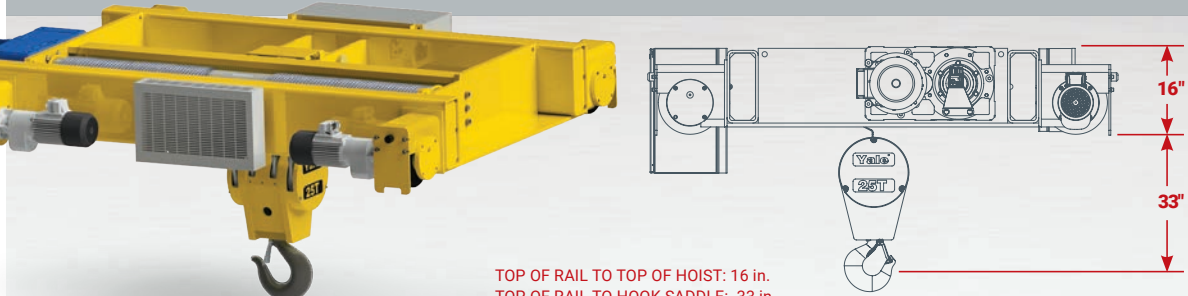

TOP OF RAIL TO TOP OF HOIST: 16 in.
TOP OF RAIL TO HOOK SADDLE: 33 in.

MAGNETEK VARIABLE FREQUENCY DRIVES

Combining Magnetek's reliable IMPULSE® Variable Frequency Drives with the LodeKing LT creates a one-of-a-kind, intelligent option for lifting applications. IMPULSE drives continuously monitor many environmental and functional components of a hoist, such as motor temperature, end of travel limits, brake functionality, motor speed, and more. Variable frequency drives maintain safe functional thresholds, which decreases mechanical fatigue and increases reliability and uptime.

IMPULSE®-VG+ Series 4 drives provide reliable, user-friendly controls and industry-leading features to keep you working safely.

MULTIPLE CONTROL OPTIONS

- 2-step infinitely variable control as standard
- Additional
 - 3-step infinitely variable control
 - 2-speed multi-step control
 - 3-speed multi-step control



THE COLUMBUS MCKINNON ADVANTAGE

Only Columbus McKinnon can offer the quality and performance of the LodeKing LT together with Magnetek, the premier name in crane controls.

AVAILABLE POWER SUPPLIES

- 208 V-3 Ph.-60 Hz
- 230 V-3 Ph.-60 Hz
- 575 V-3 Ph.-60 Hz

IMPULSE-VG+ STANDARD FEATURES

ENCODER FEEDBACK

Continuously monitors motor speed and load to ensure optimal performance and safe load control.

DYNAMIC BRAKING

Dynamically decelerates motors without the use of brakes. Brakes would only be used for parking and emergency braking, reducing brake pad wear and tear.

ANTI-SHOCK*

Automatically stabilizes loads by detecting and minimizing rapid increases in motor torque, reducing the potential for crane damage.

ULTRA-LIFT™*

Allows over speeding with light loads or empty hook. Motor speed can be adjusted to operate at peak performance.

LOAD FLOAT™

Allows a load to be held aloft at zero speed without setting the electric brake. This reduces wear and increases hoist lift response time.

BRAKE CHECK AT STOP

Tests that brakes can safely hold a load at the end of a run and the motor will maintain control of the load in case of brake failure.

SHORT CIRCUIT PROTECTION

Detects if a motor has a short circuit and can prevent additional failure of the control system.

LOAD CHECK II™*

Continuously monitors hoist overload conditions, halting upward motion and only allowing the load to be lowered.



MAGNETEK

By Columbus McKinnon

PROGRAMMABLE LIMIT SWITCHES*

Allow for configurable slow down and stop limits based on encoder pulses without additional hardware.

SLACK CABLE DETECTION*

Provides annunciation of slack cable condition to operators.

PHASE LOSS DETECTION

Detects if incoming power phase is lost and maintains a safe state of the load.

TORQUE PROVING AT START

Determines if the motor can safely control a load before opening the brake to provide additional safety.

MICRO-SPEED™*

Allows operators to scale motor speed, which is useful for load positioning.

*Features are configurable by user

INTELLI-CONNECT™ MOBILE

The LodeKing LT is available with Intelli-Connect Mobile: Wireless Drive Monitoring, Analytics, and Configuration as an option. Intelli-Connect Mobile is comprised of a wireless operator module (WOP-20) mounted on the control panel that is connected to a single Magnetek VFD via an Ethernet cable. The wireless operator creates a Wi-Fi network, which is accessible from a personal electronic device (PED), such as a smartphone or tablet via the Intelli-Connect Mobile App. Once linked, Intelli-Connect Mobile enables quick and easy programming, maintenance, monitoring, and troubleshooting of VFDs associated with your hoist or crane motion. The app is available as a free download on Google Play or the Apple® App Store.®*

With Intelli-Connect Mobile, you can continuously monitor the hoist drive and track trends and long-term information over a period of time. By tracking these trends, Intelli-Connect Mobile provides a comprehensive view of your system by monitoring runs, faults, alarms, and VFD status, including fault codes, motor voltage, current, available hoist operating life, and more. Intelli-Connect Mobile is available as an option on new LodeKing LT units or in a retrofit kit for units already in service.

FEATURES

- Easy setup and installation
- Access to the latest user manuals and quick start guides
- Parameter configuration via Quick Settings
- Parameter configuration via Keypad Emulation
- Ability to store and retrieve parameter sets (compatible with IMPULSE®•Link 5)
- Live monitoring of VFD operation
- Fault and alarm status, description, and corrective action steps
- Quick recovery from faults with built-in Fault Reset button
- Secure Wi-Fi connection and ability to customize network name and password
- Record installation date for reference
- Access to technical support information

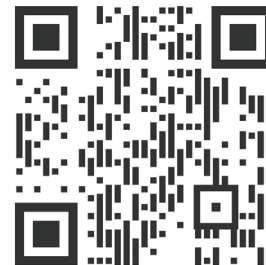
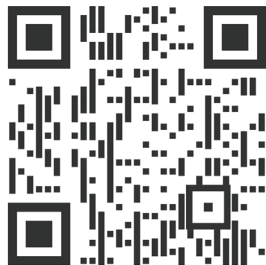

ADVANCED FEATURES

By making more VFD information easy to access with the Intelli-Connect Mobile App, you'll be able to keep the hoist operating safely and efficiently to ensure the highest levels of productivity in your facility.

- **Event History:** Comprehensive data logs during fault, alarm, and run events (Event history files are compatible with IMPULSE®•Link 5)
 - 400 alarms
 - 400 faults
 - 5,000 runs
- **Trend History:** Comprehensive data logs recorded before, during, and after run events (Trend history files are compatible with IMPULSE®•Link 5)
 - Up to 120 MB of trending data, which is equivalent to approximately 30 hours of run time
- **Inspection Logging:** Record maintenance activities and keep them stored alongside the equipment
 - 24 logs
- **Remaining Service Life:** Keep track of the remaining estimated operational life of your hoist
 - Calculations based on FEM/ISO standards (FEM9.5111)

Feature Summary
One-to-One Connection from App to IMPULSE•G+/VG+ Series 4 and G+ Mini VFDs
CM HI-Tech PC Interface
Monitoring of VFD Current, Torque, Digital I/Os, etc.
Fault Reset
Read and Write Critical Parameters (Quick Access)
Operator Emulator Mode (LCD and Buttons)
Upload and Download VFD Parameter Files (Compatible with IMPULSE•Link 5)
Documentation Access (User Manuals, Quick Start Guides, Installation Guides, FAQ, etc.)
Secure Wi-Fi Connection: Customize SSID Name and Password
Trending and Event History Log Files (Compatible with IMPULSE•Link 5)
Maintenance and Inspection Log

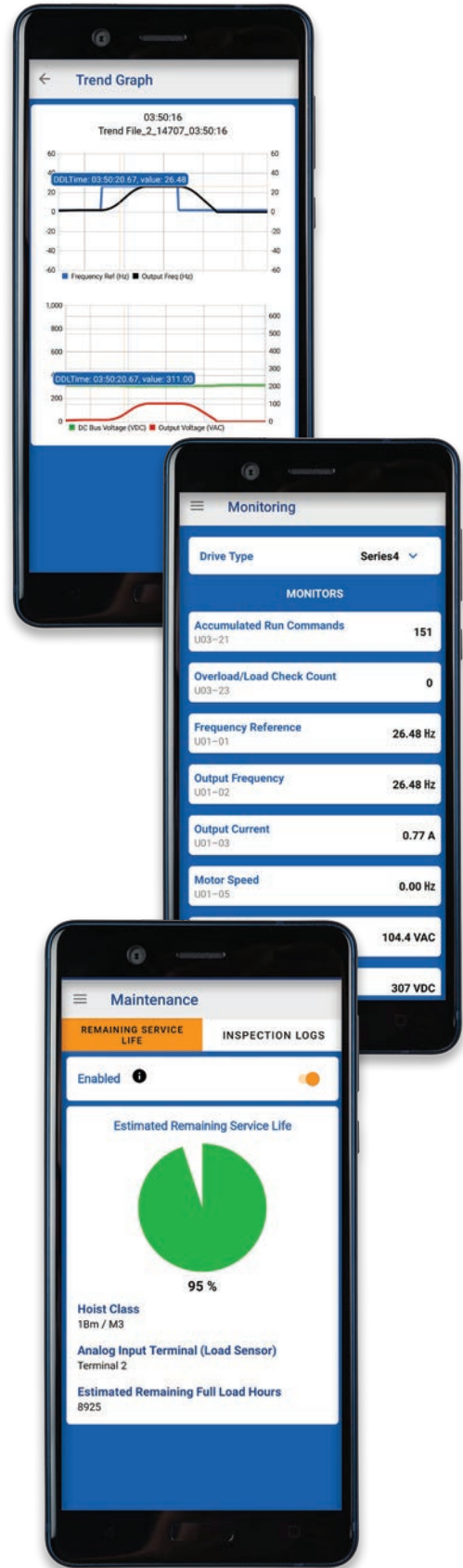

INDUSTRY-LEADING SERVICE & TRAINING

With a legacy spanning nearly 150 years Columbus McKinnon's best-in-class products are used around the world. Developed by our team of product managers, engineers, and manufacturing professionals, our products are designed for top-of-the-line performance, reliability, and safety. When you need help selecting the best Columbus McKinnon product or system for your lifting application or assistance with routine maintenance, we are here for you.

Columbus McKinnon is committed to developing products that meet the highest levels of quality, right down to the smallest details.

- Our Products
- Our Technology
- Our Service
- Our Support

KNOW HOW. KNOW WHY.

Columbus McKinnon provides expert safety training on the proper use and inspection of rigging and overhead lifting equipment.

- Comprehensive Hoist, Crane, and Rigging Training
 - In-house training at national Columbus McKinnon training centers
 - On-site training at customer facilities
- Crane & Hoist Inspection and Maintenance Training
- Crane Operator Training
- Rigging Certificate
- CMCO University™
 - Product and application knowledge to advise customers during product selection and purchasing
- And much more

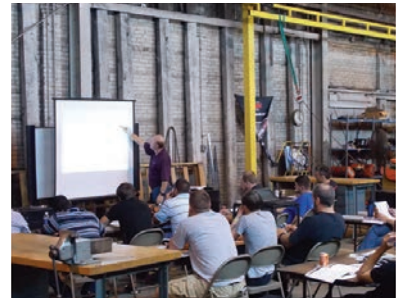



INTELLIGENT MOTION

Columbus McKinnon

CMCO.COM

Yale[®]

USA p: 800.888.0985
p: 716.689.5400
f: 716.689.5644

CAN p: 877.264.6478
p: 905.828.1526
f: 905.828.5707

wireropeapplications@cmworks.com